

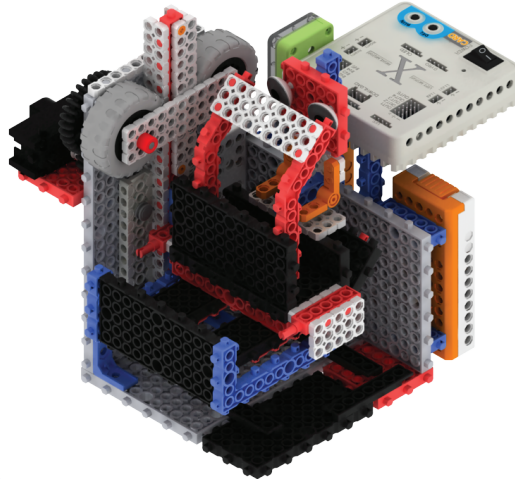

32 Elevador de coches

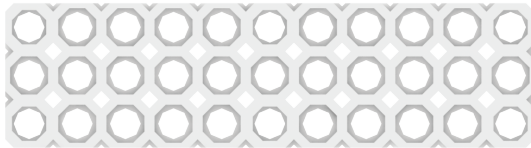

Piezas



Bloque N 3x11 (1)



Bloque N 3x9 (1)



Bloque N 2x13 (3)

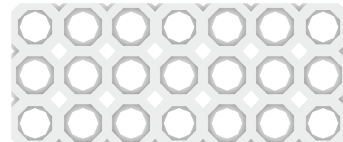

Bloque N 3x7 (1)



Bloque N 3x5 (1)



Bloque N 2x9 (2)



Bloque N 2x5 (1)



Bloque N 1x5 (2)



Bloque N 1x11 (1)

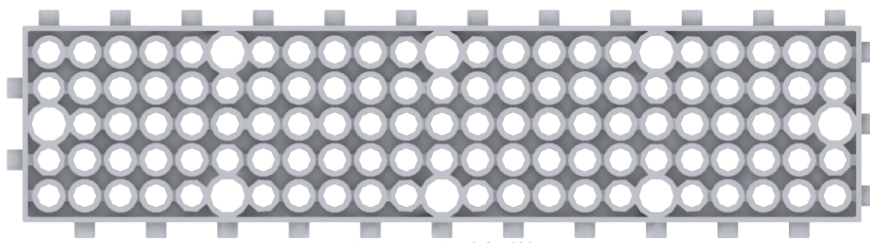

Bloque 5x23 (2)

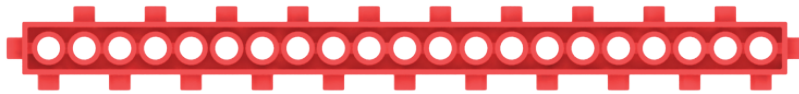

Bloque 1x21 (1)



Conector de eje (4)



Bloque de unión 2 (5)

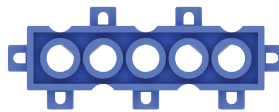

Bloque 1x5 (4)

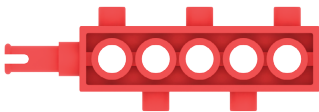

Bloque con eje (2)

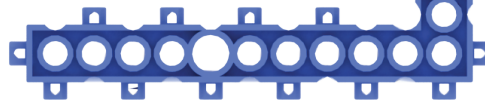

Bloque 90° (5)

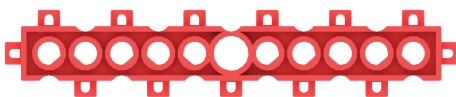

Bloque 1x11 (2)



Bloque ojo (2)



Eje M (2)

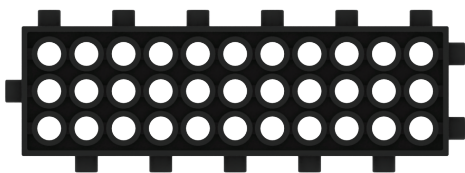

Bloque 3x11 (4)



Adaptador L (5)

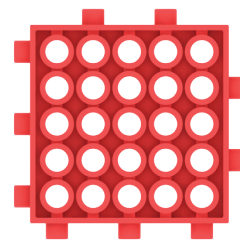

Bloque 5x5 (3)



Remache ángulo A (2)



Remache ángulo B (2)

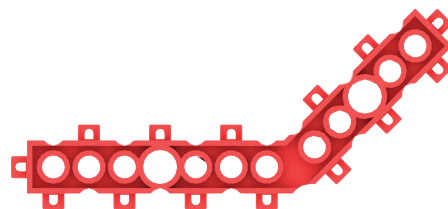

Bloque 45° (4)

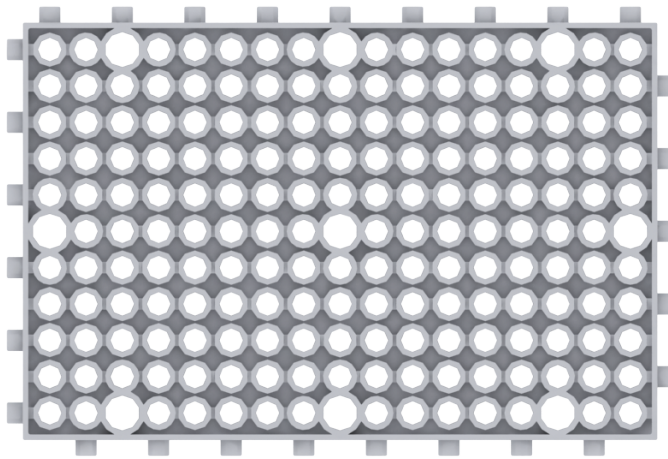

Bloque 11x17 (2)



Engranaje S (1)



Engranaje L (1)

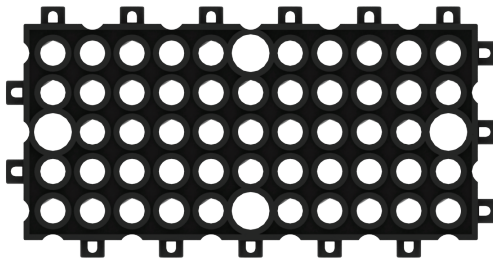

Bloque 5x11 (4)



Cable de conexión (3)



Bloque 1x11 (2)

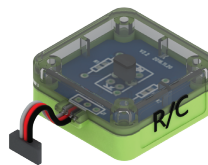

Sensor R/C (1)



Portapilas o portabaterías 1 (1)

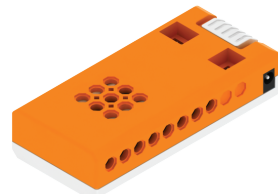

Portapilas o portabaterías 2 (2)



Goma de eje roja (8)



Remache S (6)



Remache L (2)



Arandela (7)



Rueda M (2)

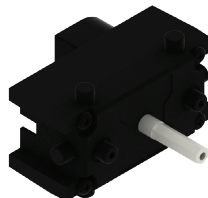

Motor 2 (1)

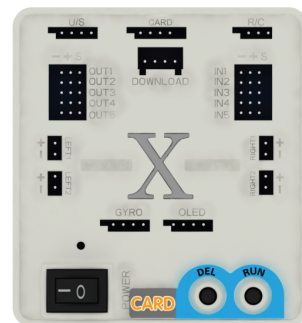

Placa base MRT Card (1)

01

x1
x1

02

x1
x2

03

x2
x2

04

Nota: el triángulo rojo ▲ señala la posición.

x1
x2

05

06

1:1

x1
x2
x1

M

07

1:1

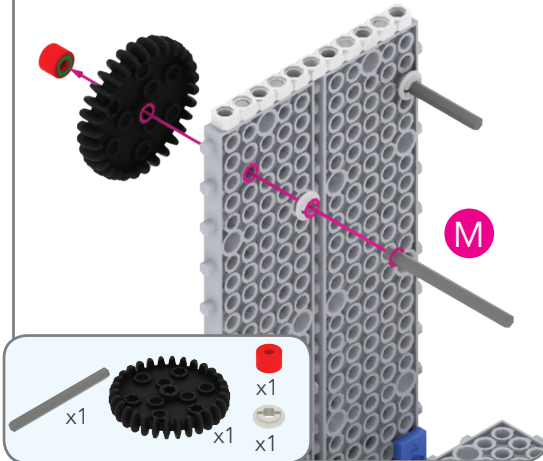

08

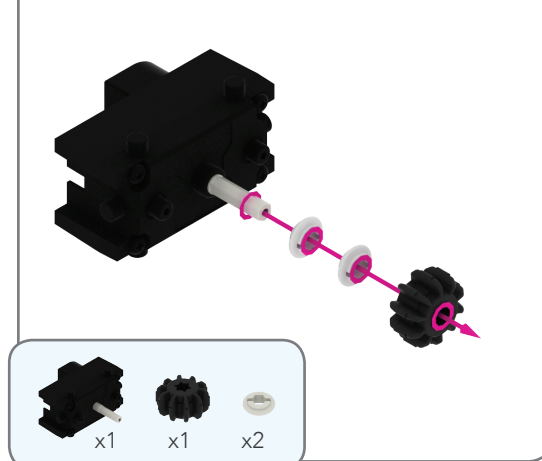

09

Nota: el triángulo rojo ▲ señala la posición.

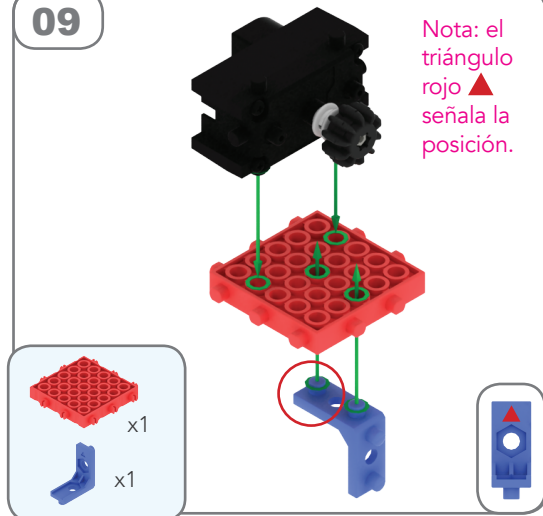

10

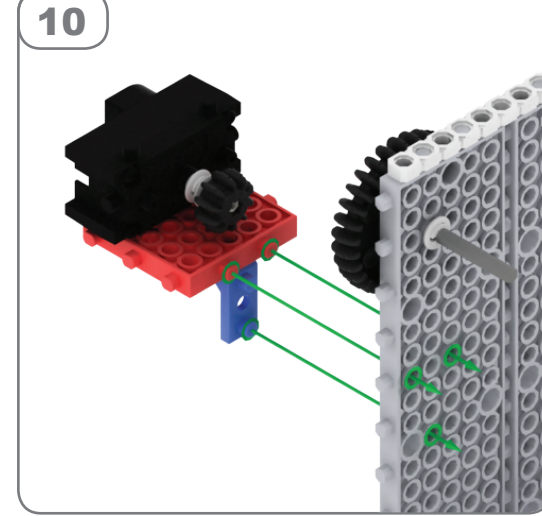

11

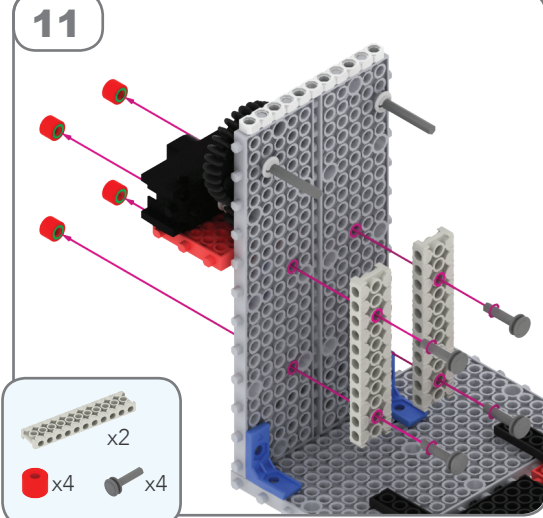

12

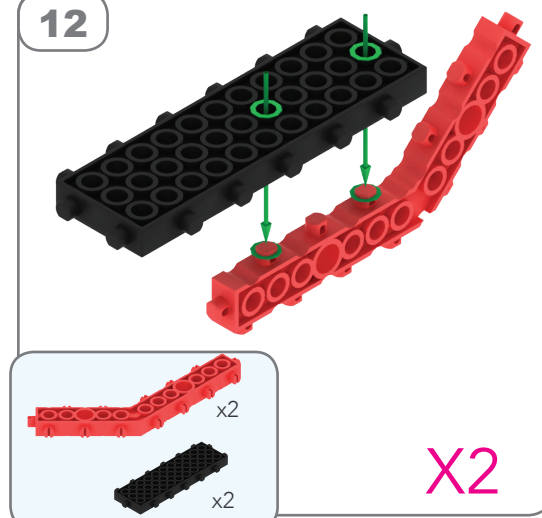

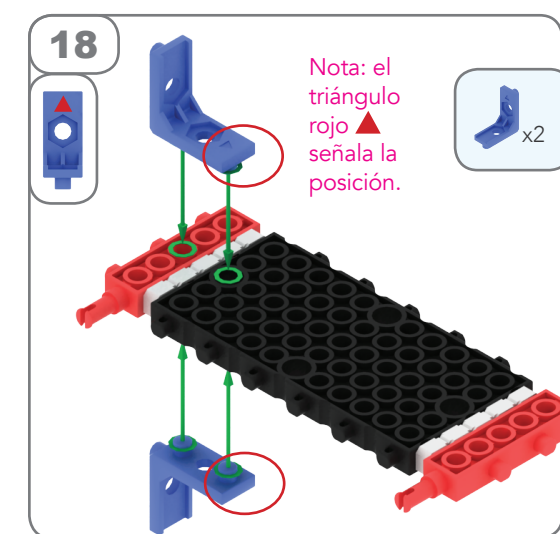
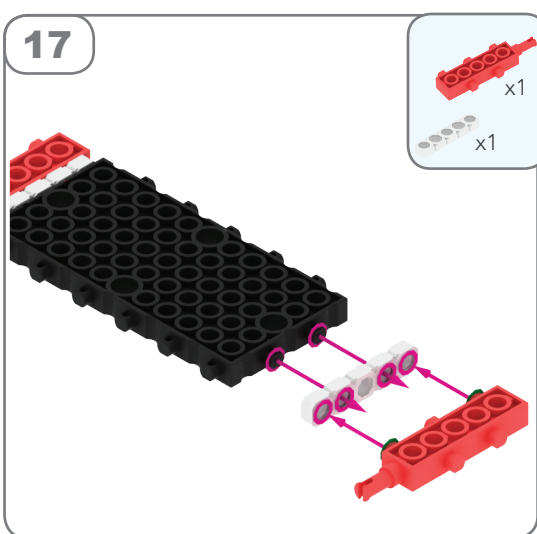
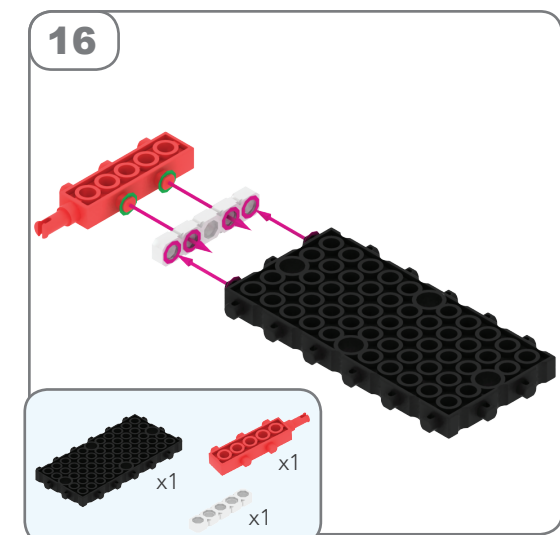
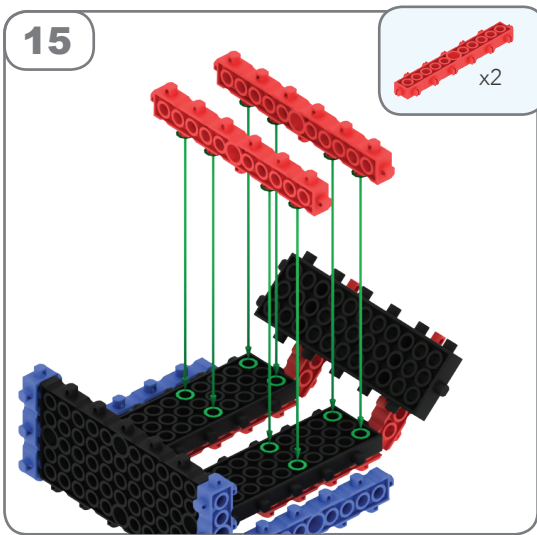
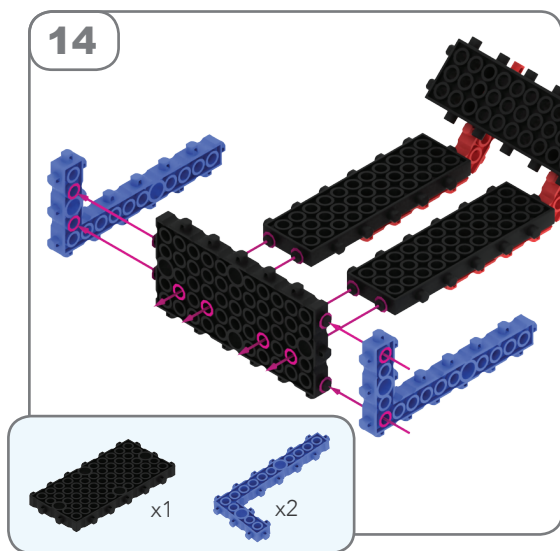
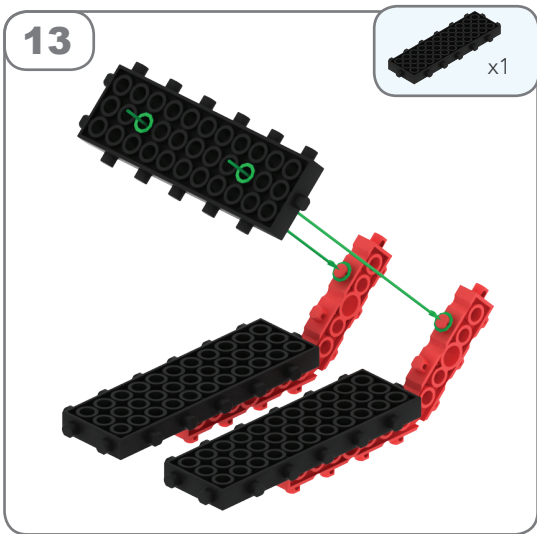

19

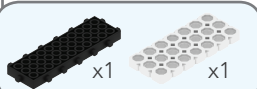
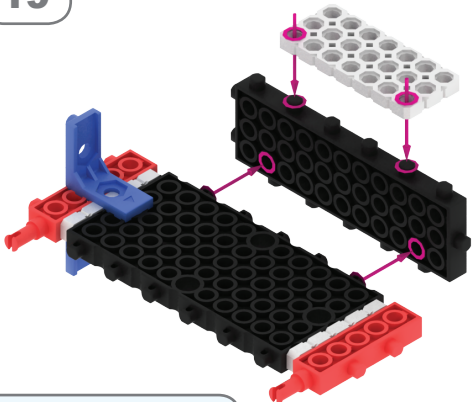

20

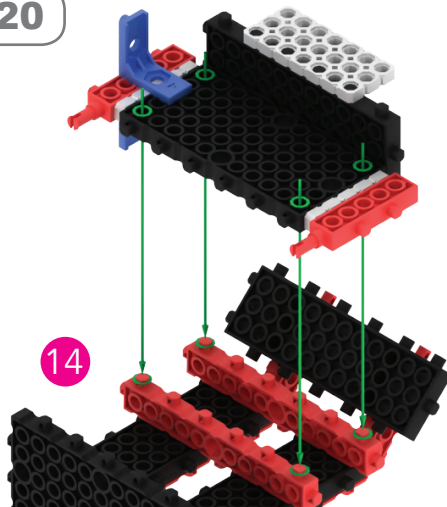

21

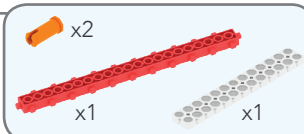
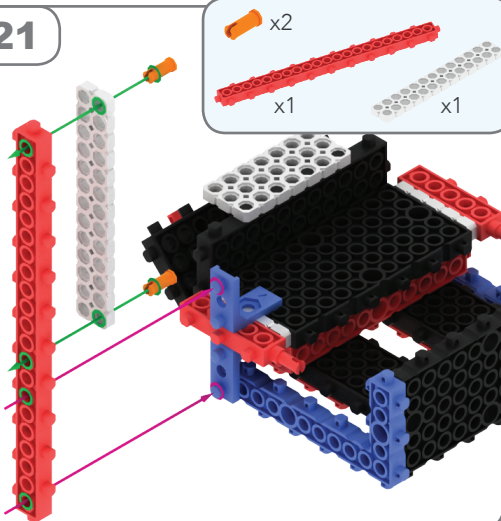

22

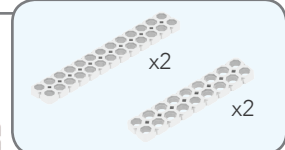
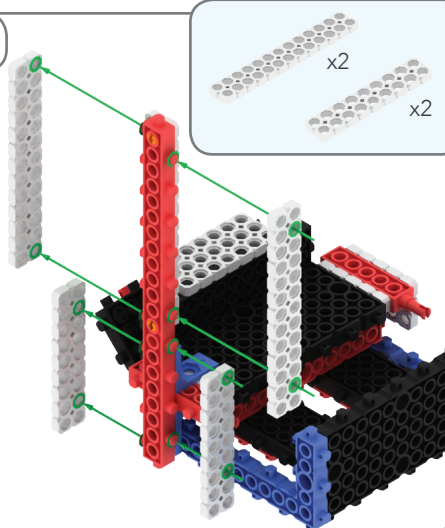

23

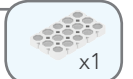
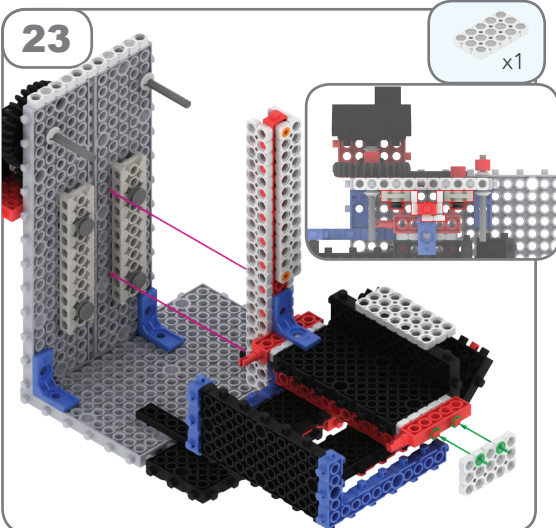

24

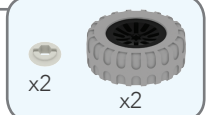
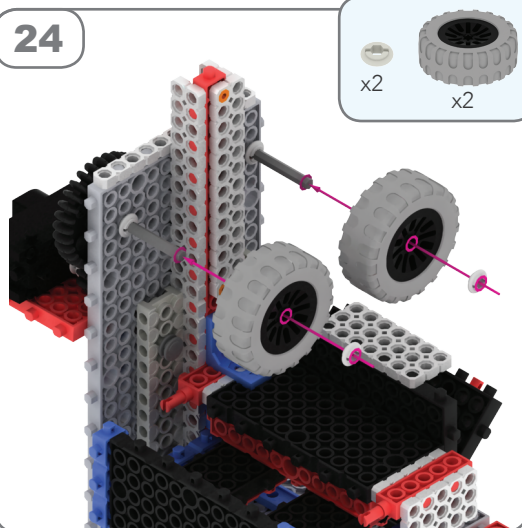

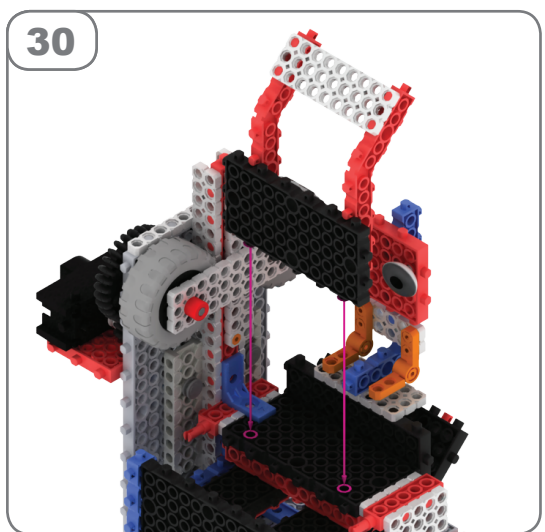
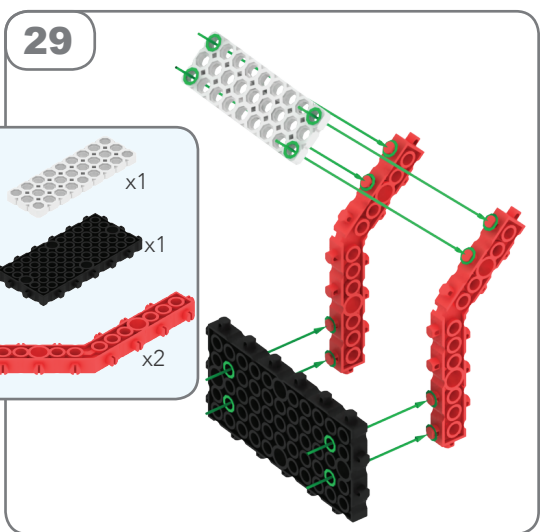
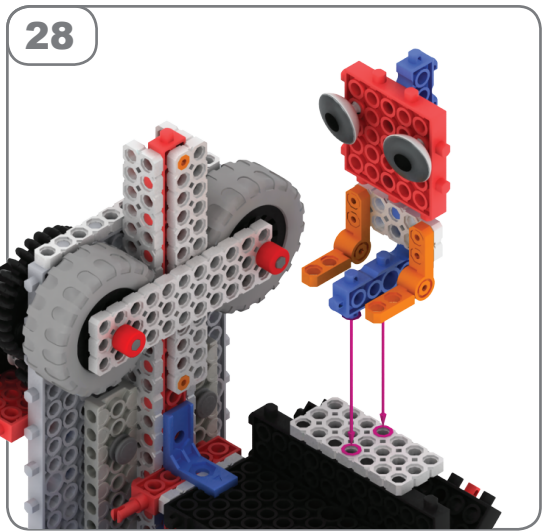
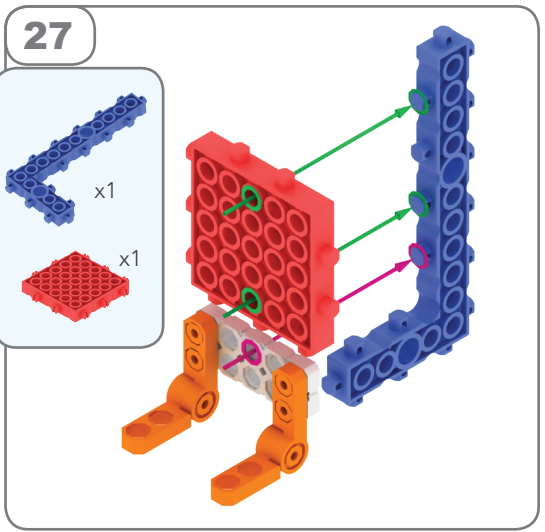
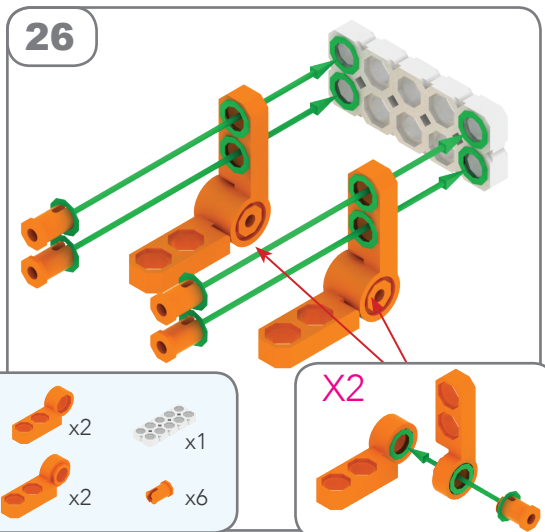
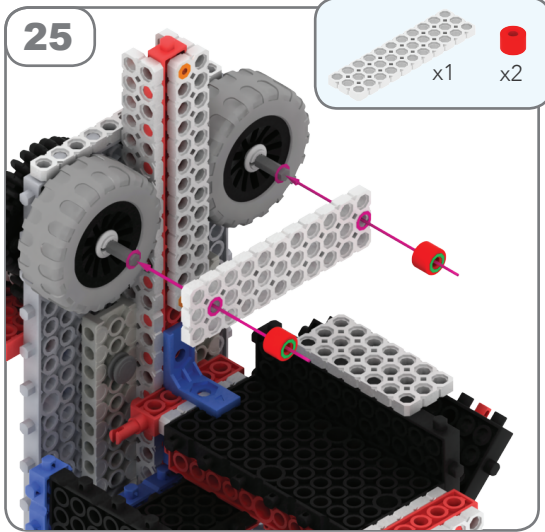

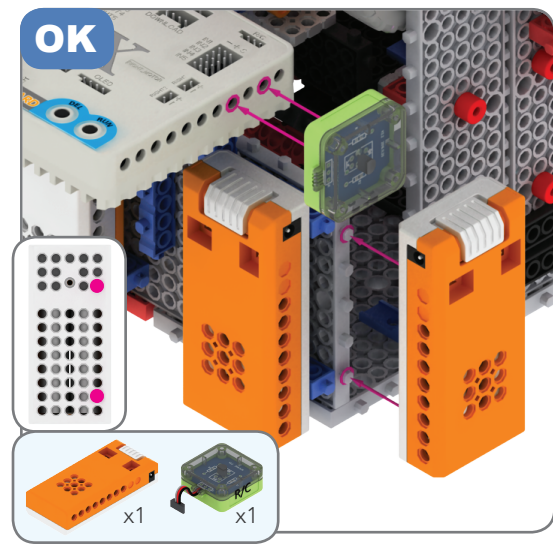
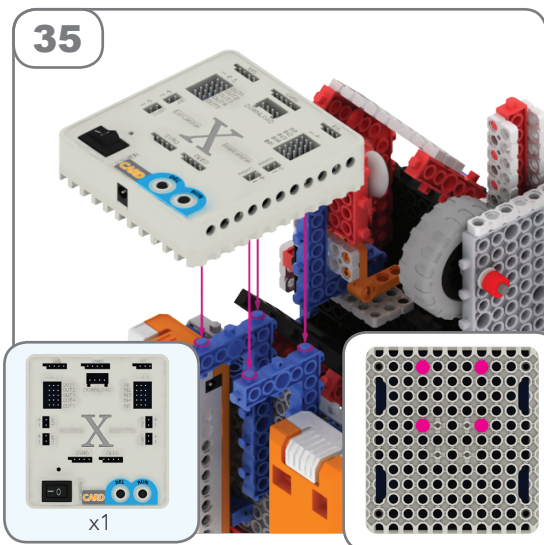
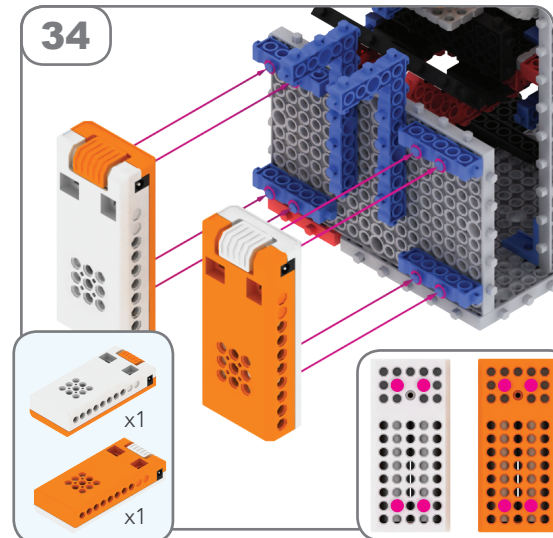
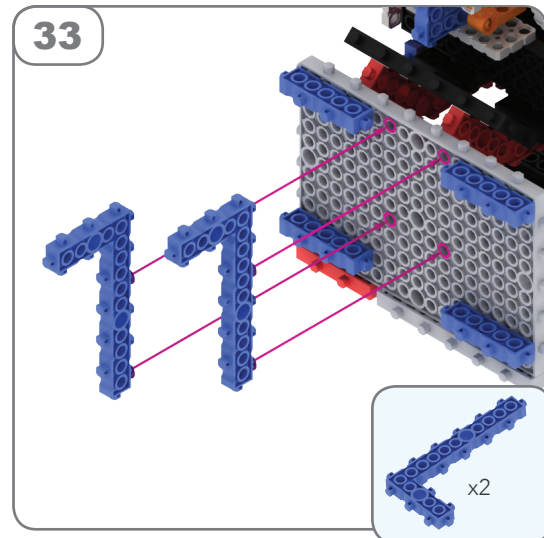
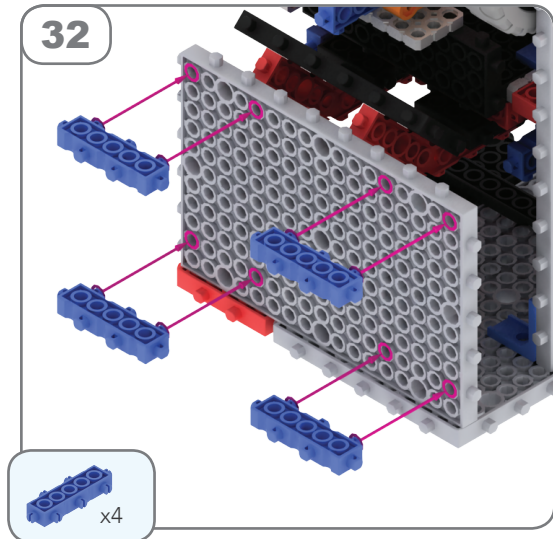
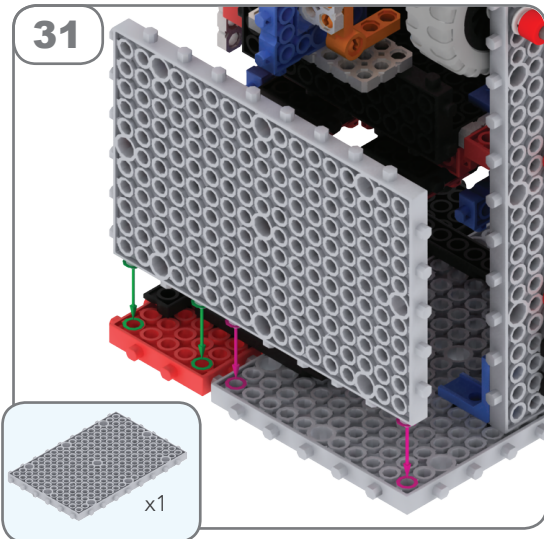

¿Cómo hacer la conexión?

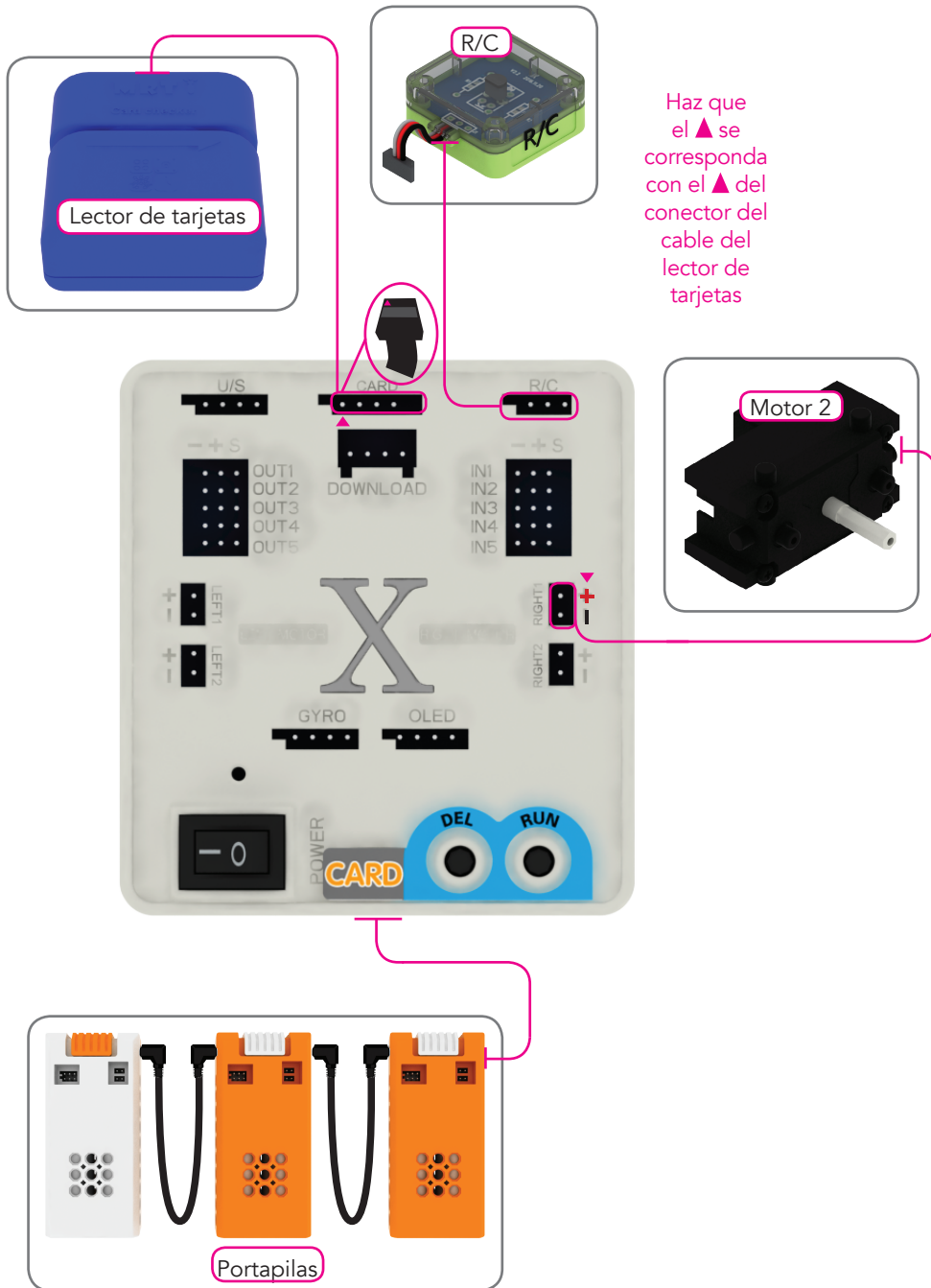

Practica



Press the key ▲



Press the key ▼



Forward

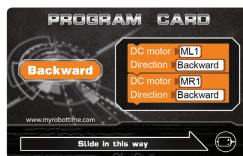

Backward

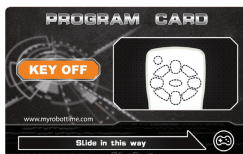

Key off



Stop



Cycle start
(all time)



Cycle end

Programación:

1. Cycle start(all time)
2. Press the key ▲
3. Forward
4. Press the key ▼
5. Backward
6. Key off
7. Stop
8. Cycle end